

APPROVED BY: _____

DATE : _____

BALANCE WEIGHTS

TOP LOAD	TOTAL	WEIGHTS
6kg	NONE	0kg
8kg	BW350-2	2.0kg
10kg	BW350-2 x 2 BW350-1	5.0kg
12kg	BW350-3 BW350-2 BW350-1	7.8kg
14kg	BW350-3 x 2 BW350-2 BW350-1	10.6kg
16kg	BW350-3 x 3 BW350-2	13.4kg
18kg	BW350-4 x 2 BW350-1	16.0kg
20kg	BW350-4 x 2 BW350-2 BW350-1	18.0kg
22kg	BW350-4 x 2 BW350-3 BW350-2	20.8kg
24kg	BW350-4 x 3 BW350-1	23.5kg
26kg	BW350-4 x 3 BW350-3	26.3kg
28kg	BW350-4 x 3 BW350-3 BW350-2	28.3kg
30kg	BW350-4 x 4 BW350-1	31.0kg
32kg	BW350-4 x 4 BW350-3	33.8kg
34kg	BW350-4 x 5	37.5kg
36kg	BW350-4 x 5 BW350-2	39.5kg
38kg	BW350-4 x 5 BW350-3	41.3kg
40kg	BW350-4 x 6	45.0kg

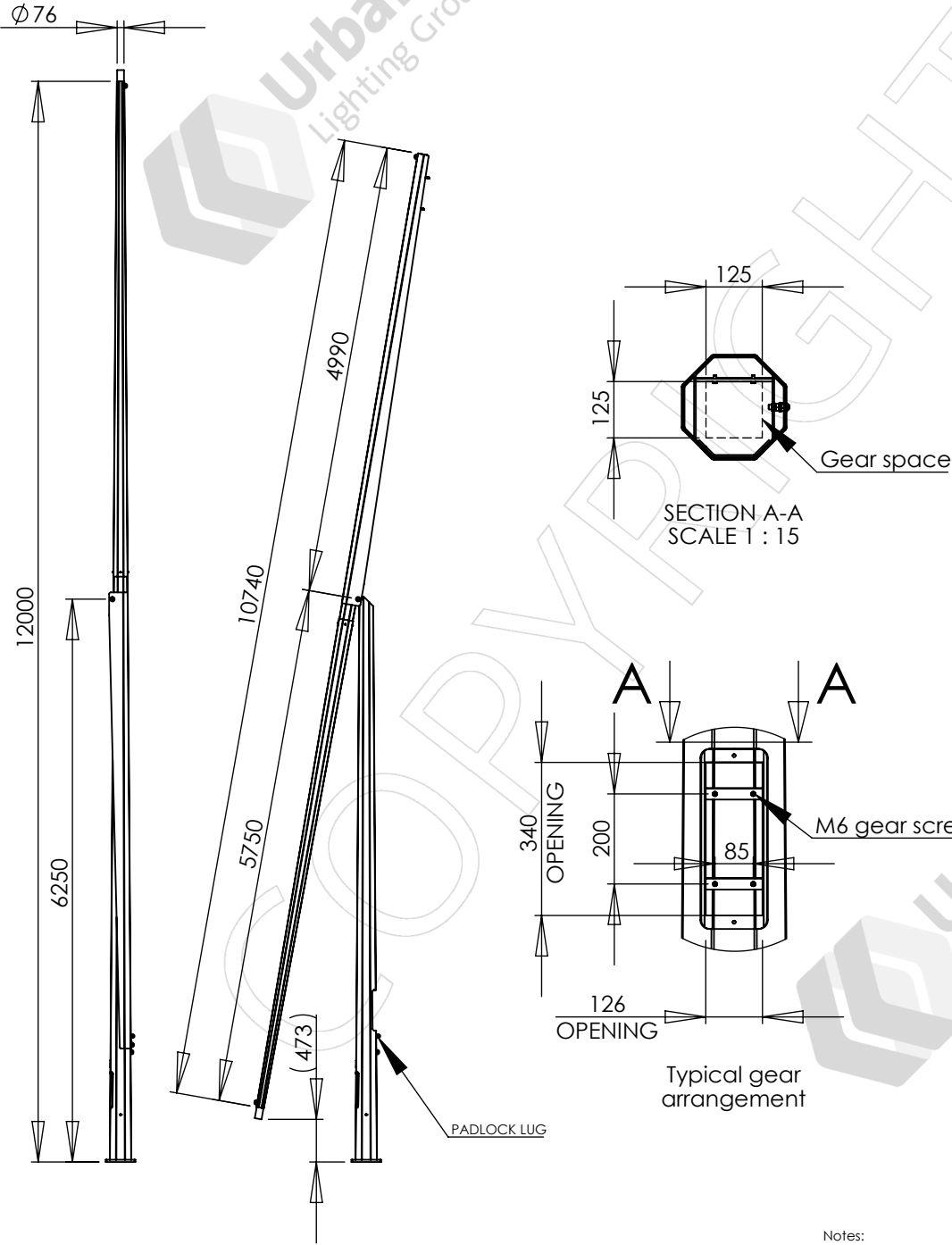

PARTS LIST					
ITEM NO.	PART NUMBER	DESCRIPTION	DRAWING NO.	REV.	QTY.
1	FL12XL2-MH	12.0 TAPERED OCTAGONAL MID-HINGED COLUMN	ADL-21364	1	1
2	UBA-M24X350	U-BOLT ASSEMBLY, M24 X 350 PCD	ADL-20299	2	1

- Notes:
- Luminaires and cabling are not included unless specifically listed on the quotation.
 - See quotation for reinforcing cage and footing details

Designed and manufactured to:
 AS 1798 Lighting poles and arms - Preferred dimensions
 AS/NZS 1170.2 Structural design actions - Part 2: Wind actions
 AS 4100 Steel structures
 AS 4680 Hot-dip galvanized (zinc) coatings
 See DS-3040 for other design standards

REV.	DESCRIPTION	DATE	BY
1	INITIAL ISSUE	2022-10-21	KG

FL12XL2-MH COLUMN	
Colour:	
Luminaires allowed for: 0.4m ² 40kg TOTAL LOAD	
Wind loads: Region A, TC 2	Ground loads: M* 21.4 kNm, V* 3.29 kN
Weight: 257kg	DO NOT SCALE
Sheet 1 of 1	A4



Urban
Lighting Group
Innovative Streetscape Solutions

Urban Lighting Group Pty Ltd
 ABN 74 638 077 684
 28 National Drive, Hallam Victoria 3803
 T 1300 088 719
 email: sales@urbanlightinggroup.com.au

Drawing No. **GA-10538**
 Revision **1**