

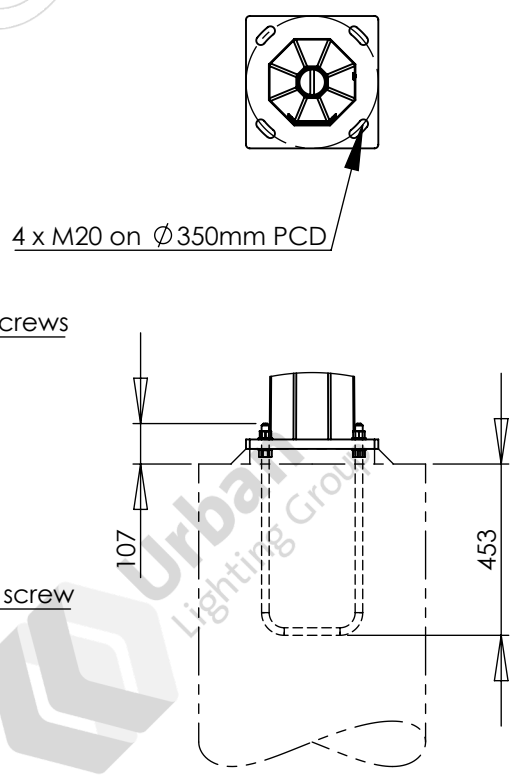

APPROVED BY: \_\_\_\_\_  
 DATE : \_\_\_\_\_

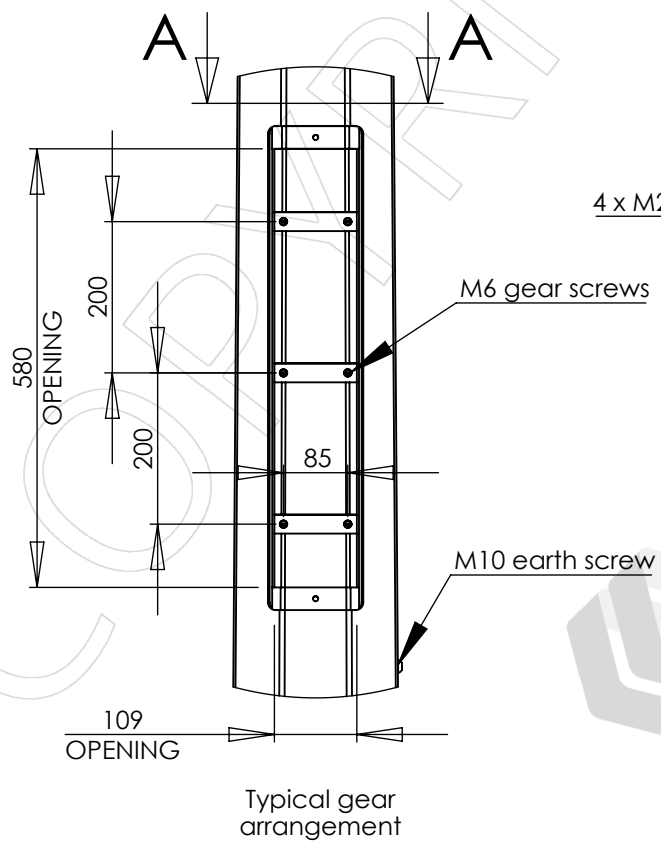
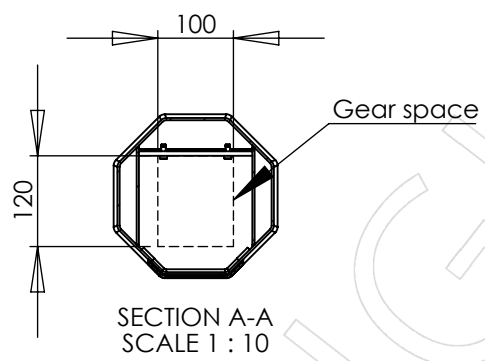
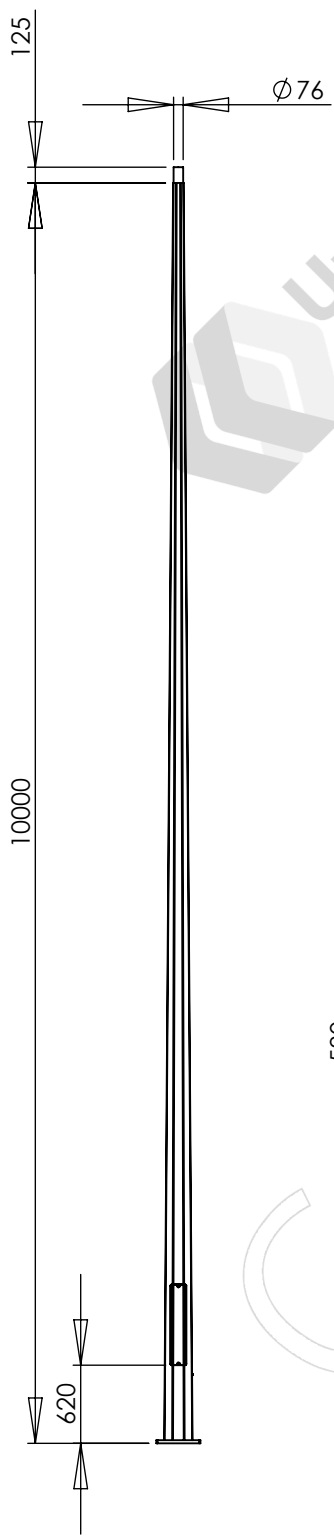

- Notes:
- Luminaires and cabling are not included unless specifically listed on the quotation.
  - See quotation for reinforcing cage and footing details

Designed and manufactured to:  
 AS 1798 Lighting poles and arms - Preferred dimensions  
 AS/NZS 1170.2 Structural design actions - Part 2: Wind actions  
 AS 4100 Steel structures  
 AS 4680 Hot-dip galvanized (zinc) coatings  
 See DS-3040 for other design standards

PARTS LIST			
ITEM NO.	PART NUMBER	DESCRIPTION	QTY.
1	FL10XL1	10.0m TAPERED OCTAGONAL COLUMN	1
2	UBA-M20X350	U-BOLT ASSEMBLY, M20 X 350	1

				FL10XL1 column		 Urban Lighting Group Innovative Streetscape Solutions Urban Lighting Group Pty Ltd ABN 74 638 077 684 28 National Drive, Hallam Victoria 3803 T 1300 088 719 email: sales@urbanlightinggroup.com.au
				Colour:		
				Luminaires allowed for: 0.6m <sup>2</sup> 60kg total load		
1	Initial issue	2022-05-18	KG	Wind loads: Region A, TC 2	Ground loads: M* 17.8 kNm, V* 3.00 kN	Drawing No. GA-10437
This drawing is the property of Urban Lighting Group Pty Ltd. No copies may be made without written permission				Weight: 154kg	DO NOT SCALE	Sheet 1 of 1
						Revision 1