

APPROVED BY: \_\_\_\_\_  
 DATE : \_\_\_\_\_

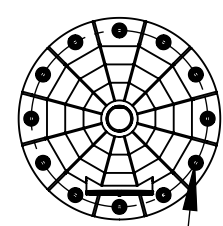

12 x M30 on  $\phi$  700mm PCD

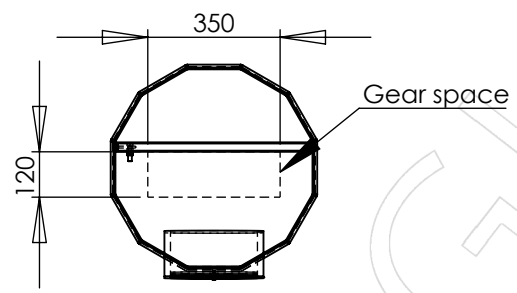
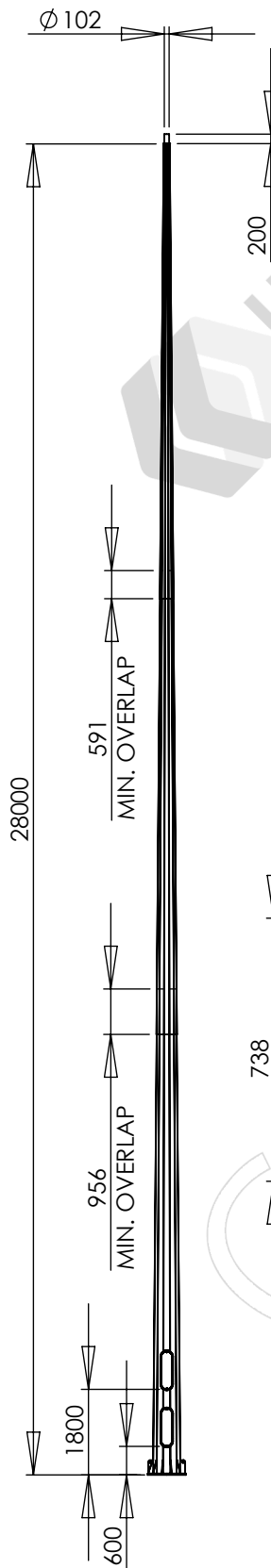
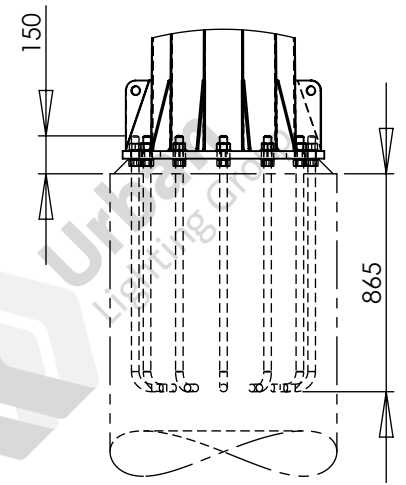
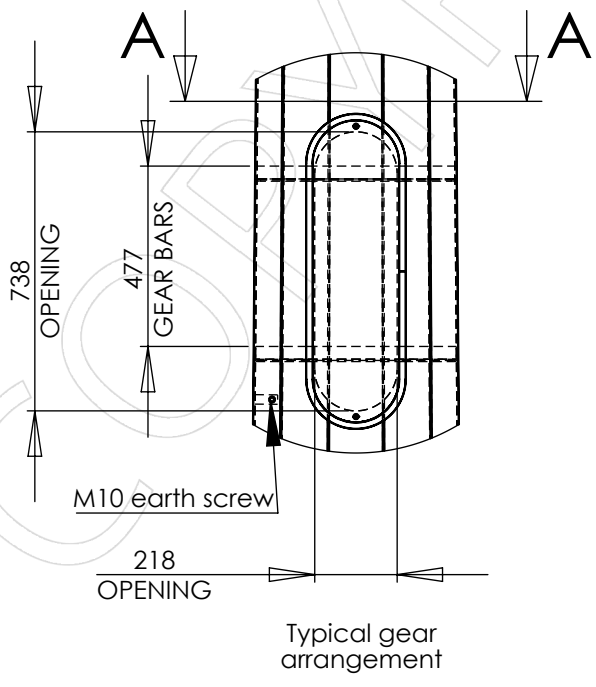

- Notes:
- Luminaires and cabling are not included unless specifically listed on the quotation.
  - See quotation for reinforcing cage and footing details

Designed and manufactured to:  
 AS 1798 Lighting poles and arms - Preferred dimensions  
 AS/NZS 1170.2 Structural design actions - Part 2: Wind actions  
 AS 4100 Steel structures  
 AS 4680 Hot-dip galvanized (zinc) coatings  
 See DS-3040 for other design standards

PARTS LIST					
ITEM NO.	PART NUMBER	DESCRIPTION	DRAWING NO.	REV.	QTY.
1	FL28-D3-102575	28.0m HIGH MAST COLUMN	ADL-21377	1	1
2	FBA-12XM30X700	FOUNDATION BOLT ASSEMBLY, 12 X M30 ON 700mm PCD			1

REV.	DESCRIPTION	DATE	BY
1	INITIAL ISSUE	2022-11-04	KG

FL28-D3-102575 column			
Colour:			
Luminaires allowed for: 1.75 m <sup>2</sup> 155kg total load			
Wind loads: Region A, TC 2		Ground loads: M* 277 kNm, V* 18.7 kN	
Weight: 1299kg		DO NOT SCALE	

Urban Lighting Group  
 Innovative Streetscape Solutions

Urban Lighting Group Pty Ltd  
 ABN 74 638 077 684  
 28 National Drive, Hallam Victoria 3803  
 T 1300 088 719  
 email: sales@urbanlightinggroup.com.au

Drawing No. GA-10562  
 Revision 1