

APPROVED BY: _____
 DATE : _____

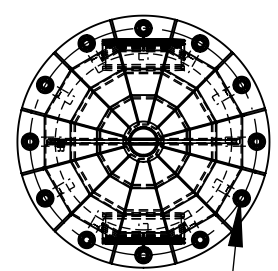

12 x M36 on \varnothing 900mm PCD

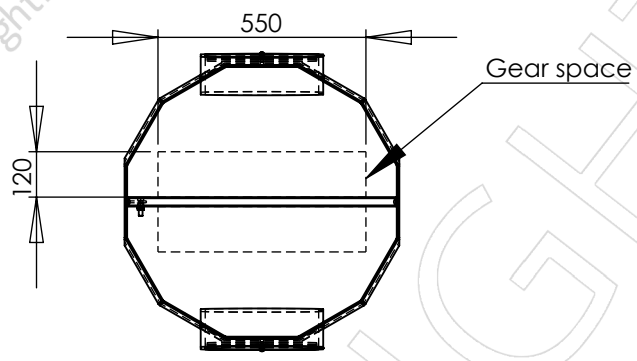
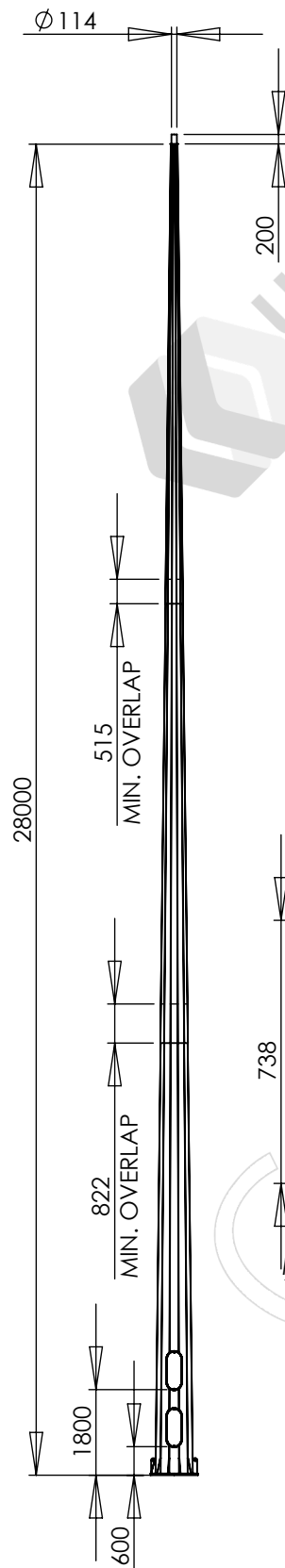
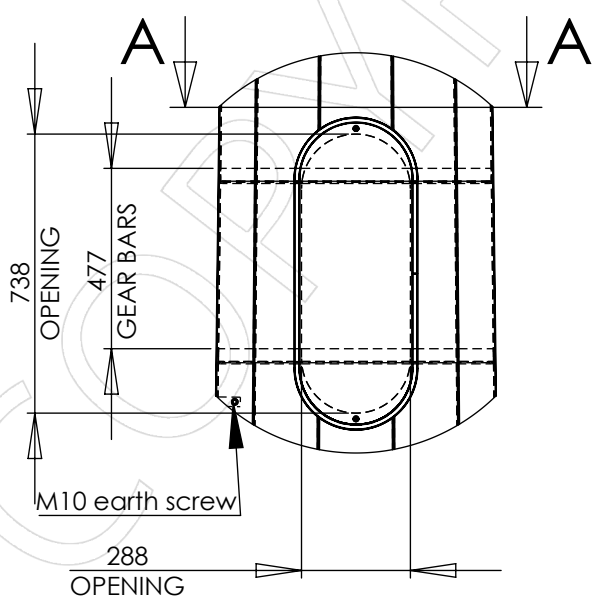

Typical gear arrangement

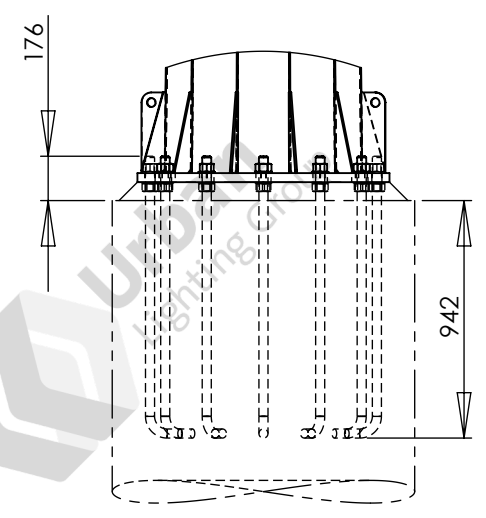

Notes:
 1. Luminaires and cabling are not included unless specifically listed on the quotation.
 2. See quotation for reinforcing cage and footing details

Designed and manufactured to:
 AS 1798 Lighting poles and arms - Preferred dimensions
 AS/NZS 1170.2 Structural design actions - Part 2: Wind actions
 AS 4100 Steel structures
 AS 4680 Hot-dip galvanized (zinc) coatings
 See DS-3040 for other design standards

PARTS LIST					
ITEM NO.	PART NUMBER	DESCRIPTION	DRAWING NO.	REV.	QTY.
1	FL28-D3-114785	28.0m HIGH MAST LIGHTING COLUMN	ADL-21379	1	1
2	FBA-12XM36X900	FOUNDATION BOLT ASSEMBLY, 12 X M36 ON 900mm PCD			1

REV.	DESCRIPTION	DATE	BY
1	INITIAL ISSUE	2022-11-04	KG

FL28-D3-114785 column	
Colour:	
Luminaires allowed for: 5.6m ² 485kg total load	
Wind loads: Region A, TC 2	Ground loads: M* 509 kNm, V* 29.8 kN
Weight: 1785kg	DO NOT SCALE
Sheet 1 of 1	A4

Urban Lighting Group
 Innovative Streetscape Solutions

Urban Lighting Group Pty Ltd
 ABN 74 638 077 684
 28 National Drive, Hallam Victoria 3803
 T 1300 088 719
 email: sales@urbanlightinggroup.com.au

Drawing No. GA-10564
 Revision 1