

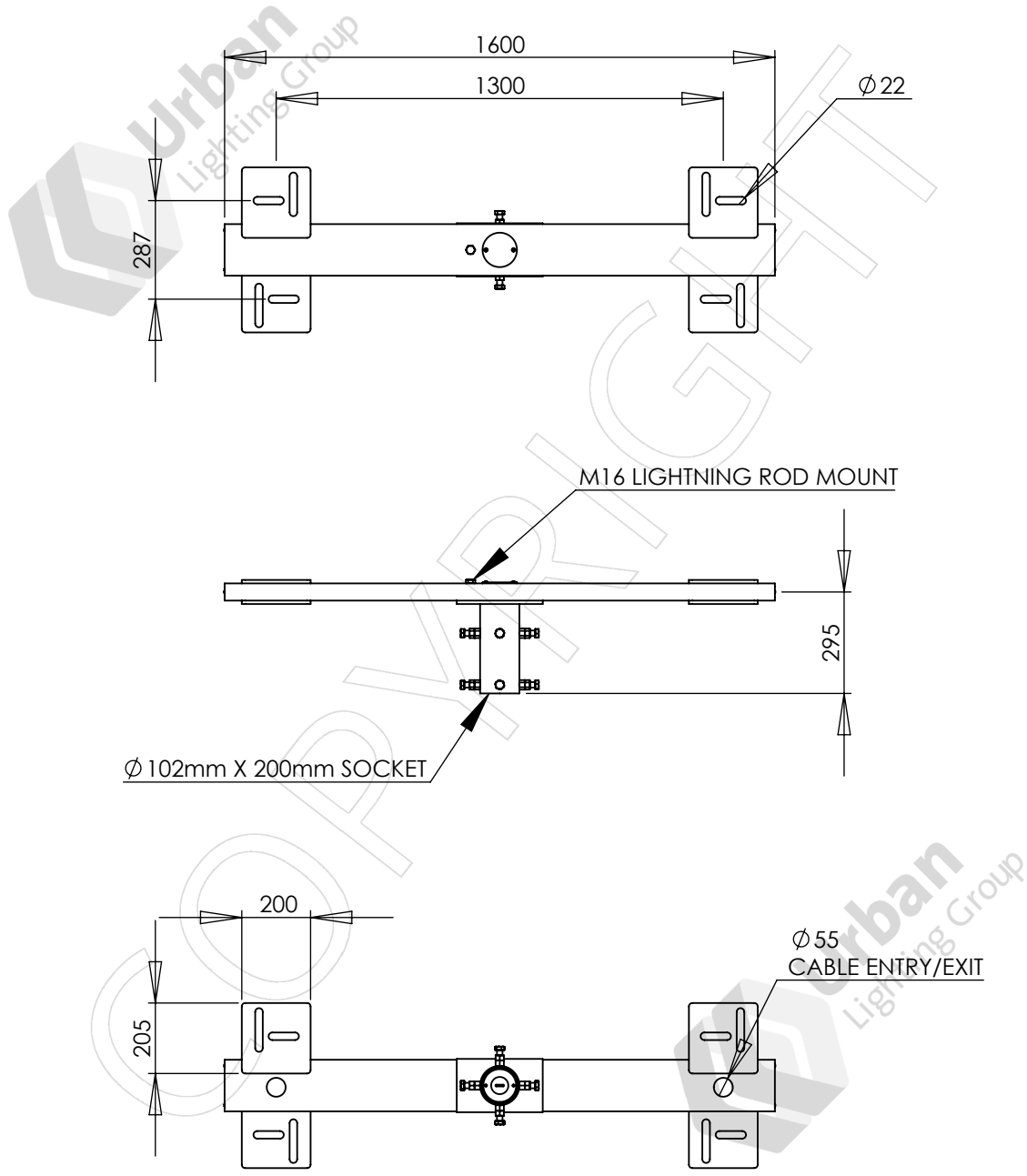

APPROVED BY: \_\_\_\_\_  
 DATE : \_\_\_\_\_



- Notes:
1. Dual bolt mount accepts luminaire mounts with  $\varnothing 20$  holes or slots at 55mm to 100mm pitch. This allows for 45° outward and 20° inward aiming when both bolts are used.
  2. Supplied with M20 x 60mm galvanized luminaire fixing bolts.
  3. Luminaires and cabling are not included unless specifically listed on the quotation.

Designed and manufactured to:  
 AS 1798 Lighting poles and arms - Preferred dimensions  
 AS/NZS 1170.2 Structural design actions - Part 2: Wind actions  
 AS 4100 Steel structures  
 AS 4680 Hot-dip galvanized (zinc) coatings  
 See DS-3040 for other design standards

PARTS LIST					
ITEM NO.	PART NUMBER	DESCRIPTION	DRAWING NO.	REV.	QTY.
1	HH4S-1300-1.6	1.6m 4 WAY STRAIGHT HEADFRAME	ADL-20898	3	1

REV.	DESCRIPTION	DATE	BY	HH4S-1300-1.6 4 Way High Mast Headframe			 <b>Urban Lighting Group</b> Innovative Streetscape Solutions Urban Lighting Group Pty Ltd ABN 74 638 077 684 28 National Drive, Hallam Victoria 3803 T 1300 088 719 email: sales@urbanlightinggroup.com.au	
1	INITIAL ISSUE	2022-11-08	KG					
Colour:								
Maximum load per mount: 4 x 0.75m <sup>2</sup> 50kg luminaires								
Wind loads: Region A, TC 2				Headframe / bracket ESA: 0.10m <sup>2</sup>			Drawing No. GA-10551	
Weight: 41kg				DO NOT SCALE		Sheet 1 of 1	A4	Revision 1

This drawing is the property of Urban Lighting Group Pty Ltd.  
 No copies may be made without written permission