

APPROVED BY: _____
 DATE : _____

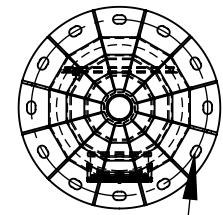

12 x M30 on ϕ 700mm PCD

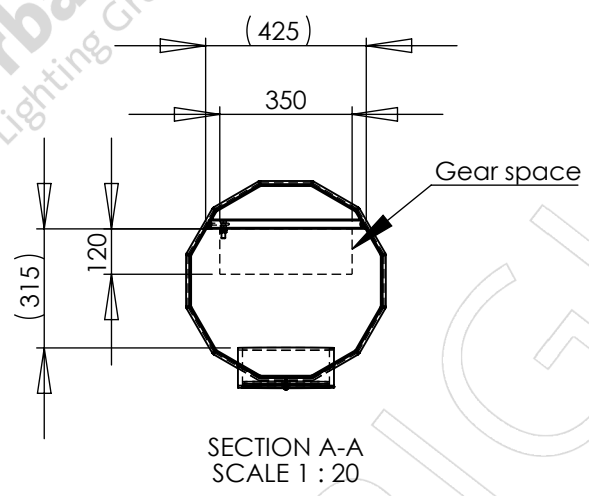
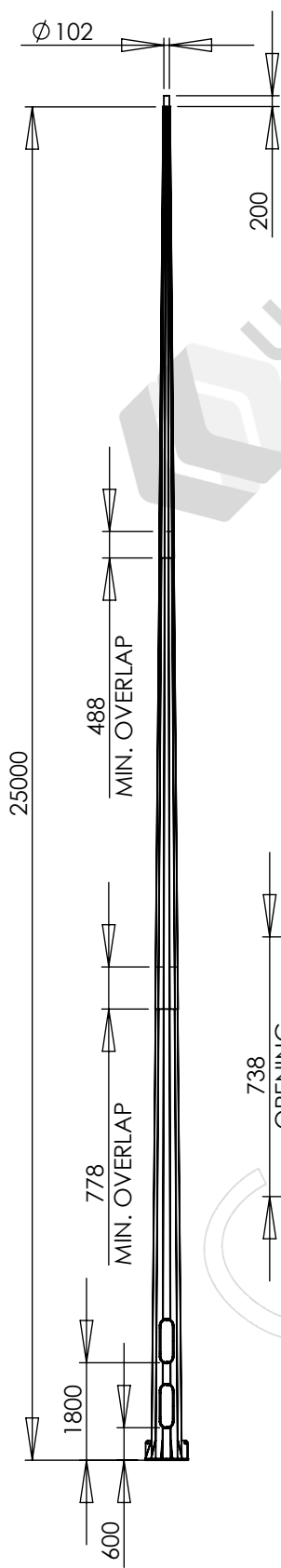
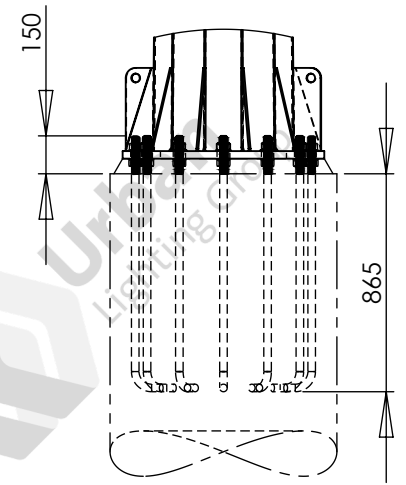
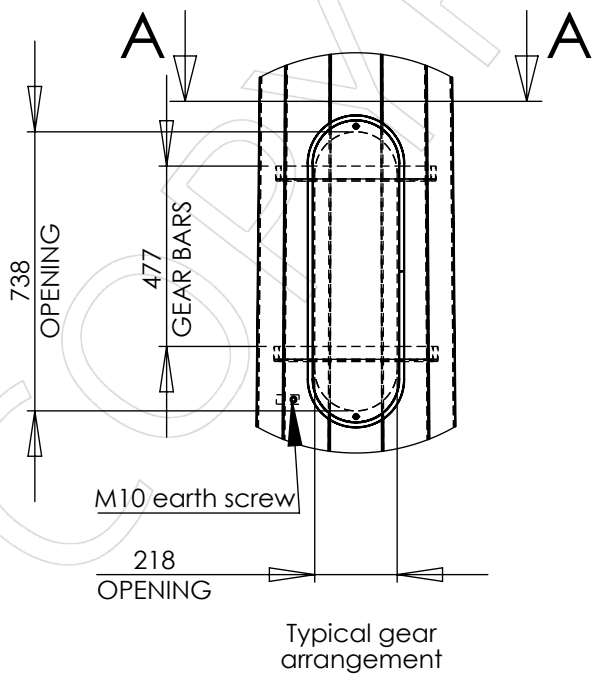

- Notes:
- Luminaires and cabling are not included unless specifically listed on the quotation.
 - See quotation for reinforcing cage and footing details

Designed and manufactured to:
 AS 1798 Lighting poles and arms - Preferred dimensions
 AS/NZS 1170.2 Structural design actions - Part 2: Wind actions
 AS 4100 Steel structures
 AS 4680 Hot-dip galvanized (zinc) coatings
 See DS-3040 for other design standards

PARTS LIST					
ITEM NO.	PART NUMBER	DESCRIPTION	DRAWING NO.	REV.	QTY.
1	FL25-D3-102560	25.0m HIGH MAST COLUMN	ADL-21285	2	1
2	FBA-12XM30X700	FOUNDATION BOLT ASSEMBLY, 12 X M30 ON 700mm PCD			1

REV.	DESCRIPTION	DATE	BY	APP.
1	INITIAL ISSUE	2022-05-05	KG	KG
2	COLUMN UPDATED	2023-03-10	KG	RH

FL25-D3-102560 column	
Colour:	
Luminaires allowed for: 1.75 sq.m 155kg total load	
Wind loads: Region A, TC 2	Ground loads: M* 218 kNm, V* 16.3 kN
Weight: 1130kg	

Urban Lighting Group
 Innovative Streetscape Solutions

Urban Lighting Group Pty Ltd
 ABN 74 638 077 684
 28 National Drive, Hallam Victoria 3803
 T 1300 088 719
 email: sales@urbanlightinggroup.com.au

Drawing No. GA-10423
 Revision 2