

APPROVED BY: \_\_\_\_\_  
 DATE : \_\_\_\_\_

BALANCE WEIGHTS		
TOP LOAD	WEIGHTS	
36kg	NONE	0.0kg
38kg	BW350-2	2.0kg
40kg	BW350-3	3.8kg
45kg	BW350-3 x 2 BW350-2	9.6kg
50kg	BW350-4 BW350-3 BW350-2 BW350-1	14.3kg
55kg	BW350-4 x 2 BW350-2 x 2 BW350-1	20.0kg
60kg	BW350-4 x 3 BW350-2 BW350-1	25.5kg
65kg	BW350-4 x 4 BW350-1	31.0kg
70kg	BW350-4 x 4 BW350-3	33.8kg
75kg	BW350-4 x 5 BW350-3	41.3kg
80kg	BW350-4 x 6 BW350-2	47.0kg
85kg	BW350-4 x 6 BW350-3	48.8kg
90kg	BW350-4 x 7 BW350-3	56.3kg

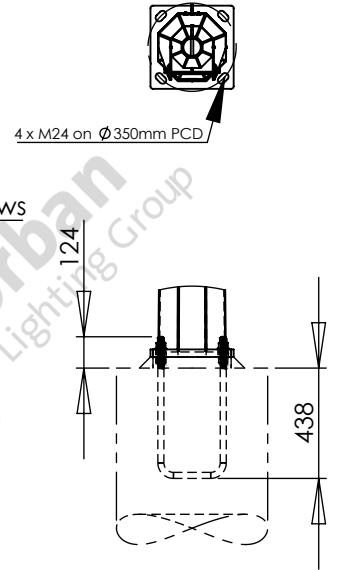
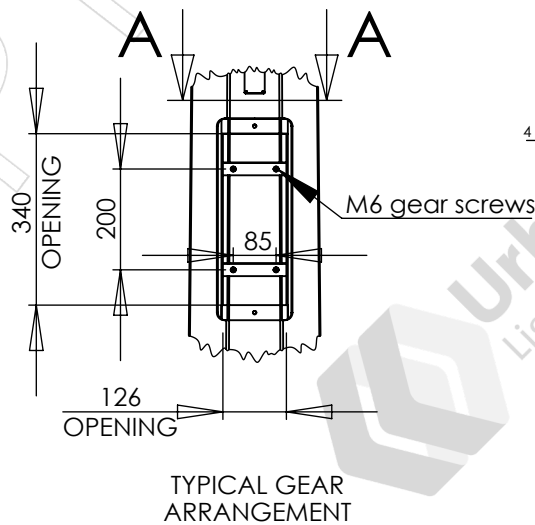
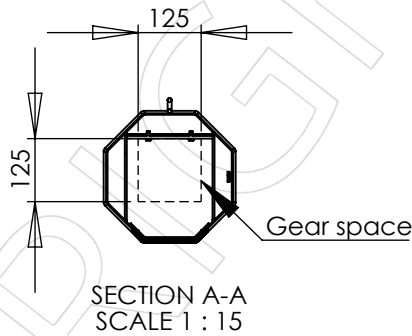
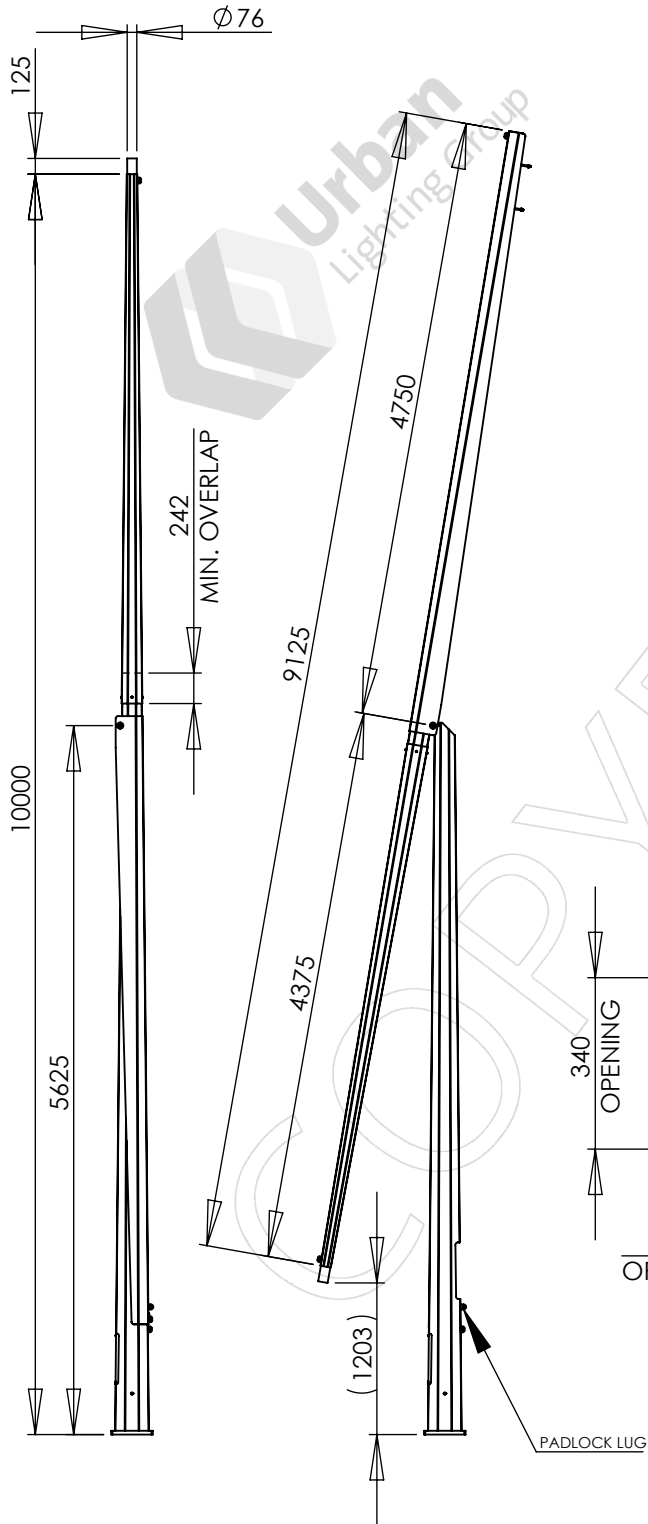

Notes:

- Luminaires and cabling are not included unless specifically listed on the quotation.
- See quotation for reinforcing cage and footing details

Designed and manufactured to:  
 AS 1798 Lighting poles and arms - Preferred dimensions  
 AS/NZS 1170.2 Structural design actions - Part 2: Wind actions  
 AS 4100 Steel structures  
 AS 4680 Hot-dip galvanized (zinc) coatings  
 See DS-3040 for other design standards

PARTS LIST					
ITEM NO.	PART NUMBER	DESCRIPTION	DRAWING NO.	REV.	QTY.
1	FL10L2-MH	COLUMN, 10.0m 2 SECTION MID-HINGED, 36kg - 90kg	ADL-21545	1	1
2	UBA-M24X350	U-BOLT ASSEMBLY, M24X350 PCD	ADL-20299	3	1

REV.	DESCRIPTION	DATE	BY	APP.
1	INITIAL ISSUE	2023-10-13	KG	ME

COLUMN, FL10L2-MH, 10.0m 2 SECTION MID-HINGED, 36kg - 90kg

COATING:  
 MAXIMUM LOAD: 0.9m<sup>2</sup> 90kg

WIND REGION: A, TC 2

GROUND LOAD: M\* 22.3 kNm, V\* 3.63 kN

WEIGHT: 264kg

DO NOT SCALE

SHEET 1 OF 1

A4



Urban Lighting Group Pty Ltd  
 ABN 74 638 077 684  
 28 National Drive, Hallam Victoria 3803  
 T 1300 088 719  
 email: sales@urbanlightinggroup.com.au

DRAWING NO. GA-10778

REVISION 1