

APPROVED BY: \_\_\_\_\_

DATE : \_\_\_\_\_

Ø76

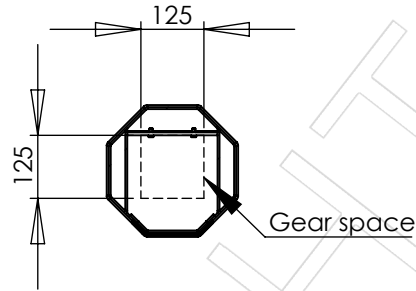

SECTION A-A  
SCALE 1 : 15

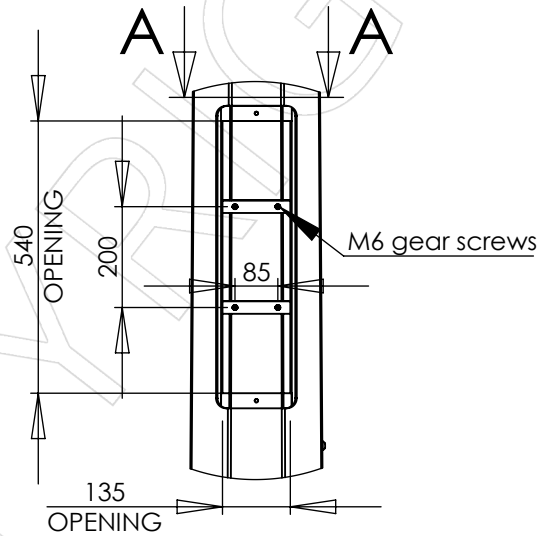

Typical gear arrangement



Notes:

- Luminaires and cabling are not included unless specifically listed on the quotation.
- See quotation for reinforcing cage and footing details

Designed and manufactured to:  
 AS 1798 Lighting poles and arms - Preferred dimensions  
 AS/NZS 1170.2 Structural design actions - Part 2: Wind actions  
 AS 4100 Steel structures  
 AS 4680 Hot-dip galvanized (zinc) coatings  
 See DS-3040 for other design standards

PARTS LIST

ITEM NO.	PART NUMBER	DESCRIPTION	DRAWING NO.	REV.	QTY.
1	FL15XL2-MH	15.0 TAPERED OCTAGONAL MID-HINGED COLUMN	ADL-21366	1	1
2	UBA-M30X350	U-BOLT ASSEMBLY, M30 x 350mm PCD	ADL-20713	1	1

REV.	DESCRIPTION	DATE	BY
1	INITIAL ISSUE	2022-10-25	KG

FL15XL2-MH COLUMN

Colour:

Luminaires allowed for: 0.6m<sup>2</sup> 60kg TOTAL LOAD

Wind loads: Region A, TC 2

Ground loads: M\* 39.8 kNm, V\* 4.82 kN

Weight: 389kg

DO NOT SCALE

Sheet 1 of 2

A4



Urban Lighting Group Pty Ltd  
 ABN 74 638 077 684  
 28 National Drive, Hallam Victoria 3803  
 T 1300 088 719  
 email: sales@urbanlightinggroup.com.au

Drawing No. GA-10539

Revision 1

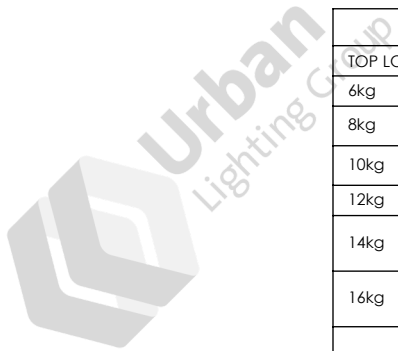

BALANCE WEIGHTS		
TOP LOAD	TOTAL	WEIGHTS
6kg	NONE	0kg
8kg	BW450-2 BW450-1	3kg
10kg	BW450-3 BW450-1	5kg
12kg	BW450-4	8kg
14kg	BW450-4 BW450-2 BW450-1	10kg
16kg	BW450-4 BW450-3 BW450-1	13kg
18kg	BW450-4 BW450-3 BW450-2 BW450-1	15kg
20kg	BW450-5 BW450-2	18kg
22kg	BW450-5 BW450-3	20kg
24kg	BW450-5 BW450-3 BW450-2 BW450-1	23kg
26kg	BW450-5 BW450-4 BW450-1	25kg
28kg	BW450-5 BW450-4 BW450-3	28kg
30kg	BW450-5 BW450-4 BW450-3 BW450-2	30kg
32kg	BW450-5 BW450-5 BW450-1	33kg
34kg	BW450-5 BW450-5 BW450-2 BW450-1	35kg
36kg	BW450-5 BW450-5 BW450-3 BW450-2	38kg
38kg	BW450-5 BW450-5 BW450-4	40kg
40kg	BW450-5 BW450-5 BW450-4 BW450-2 BW450-1	43kg
45kg	BW450-5 BW450-5 BW450-5	48kg
50kg	BW450-5 BW450-5 BW450-5 BW450-3 BW450-2 BW450-1	55kg
55kg	BW450-5 BW450-5 BW450-5 BW450-4 BW450-3 BW450-1	61kg
60kg	BW450-5 BW450-5 BW450-5 BW450-5 BW450-2 BW450-1	67kg



REV.	DESCRIPTION	DATE	BY	FL15XL2-MH COLUMN			 Urban Lighting Group Innovative Streetscape Solutions Urban Lighting Group Pty Ltd ABN 74 638 077 684 28 National Drive, Hallam Victoria 3803 T 1300 088 719 email: sales@urbanlightinggroup.com.au
1	INITIAL ISSUE	2022-10-25	KG				
				Colour:			
				Luminaires allowed for: 0.6m <sup>2</sup> 60kg TOTAL LOAD			
				Wind loads: Region A, TC 2	Ground loads: M* 39.8 kNm, V* 4.82 kN		Drawing No. GA-10539
This drawing is the property of Urban Lighting Group Pty Ltd. No copies may be made without written permission				Weight: 389kg	DO NOT SCALE	Sheet 2 of 2	A4
							Revision 1