

APPROVED BY: _____
 DATE : _____

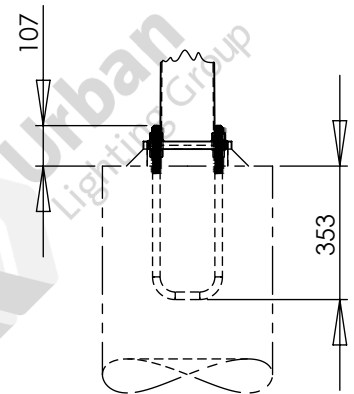
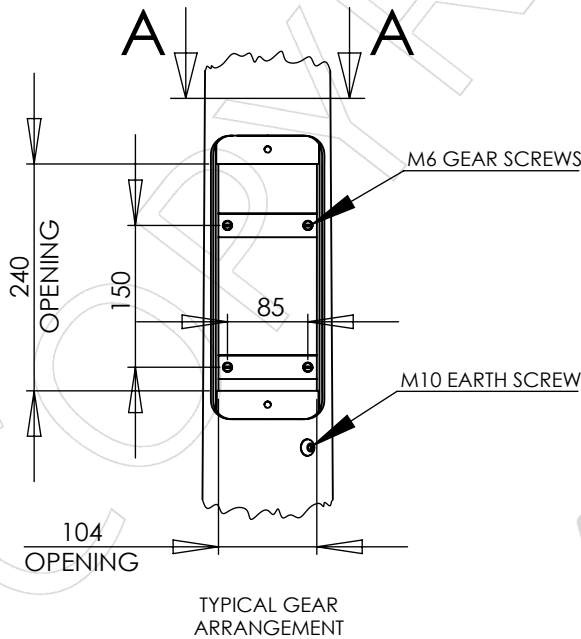
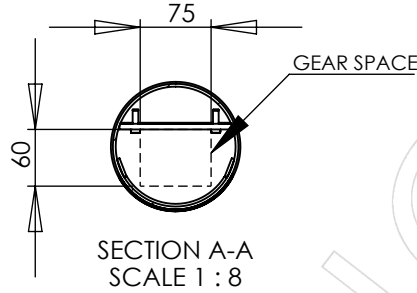
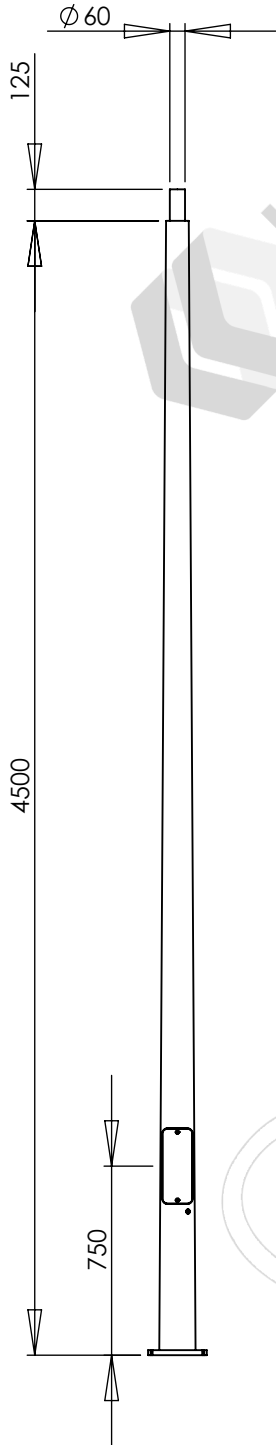

NOTES:

- LUMINAIRES AND CABLING ARE NOT INCLUDED UNLESS SPECIFICALLY LISTED ON THE QUOTATION.
- SEE QUOTATION FOR REINFORCING CAGE AND FOOTING DETAILS

DESIGNED AND MANUFACTURED TO:
 AS 1798 LIGHTING POLES AND ARMS - PREFERRED DIMENSIONS
 AS/NZS 1170.2 STRUCTURAL DESIGN ACTIONS - PART 2: WIND ACTIONS
 AS 4100 STEEL STRUCTURES
 AS 4680 HOT-DIP GALVANIZED (ZINC) COATINGS
 SEE DS-3040 FOR OTHER DESIGN STANDARDS

PARTS LIST					
ITEM NO.	PART NUMBER	DESCRIPTION	DRAWING NO.	REV.	QTY.
1	FL4.5XLR1-60	COLUMN, 4.5M TAPERED ROUND 60mm SPIGOT	ADL-20778	1	1
2	UBA-M20X233	U-BOLT ASSEMBLY, M20X233 PCD	ADL-20358	2	1

REV.	DESCRIPTION	DATE	BY	APP.
1	INITIAL ISSUE	2023-10-12	KG	ME

COLUMN, FL4.5XLR1-60, 4.5M TAPERED ROUND 60mm SPIGOT	
COATING:	
MAXIMUM LOAD: 0.6m ² 60kg	
WIND REGION: A, TC 2	GROUND LOAD: M* 4.16 kNm, V* 1.19 kN
WEIGHT: 47kg	DO NOT SCALE



Urban Lighting Group
 Innovative Streetscape Solutions

Urban Lighting Group Pty Ltd
 ABN 74 638 077 684
 28 National Drive, Hallam Victoria 3803
 T 1300 088 719
 email: sales@urbanlightinggroup.com.au

DRAWING NO. GA-10777

REVISION 1