

APPROVED BY: _____
 DATE : _____

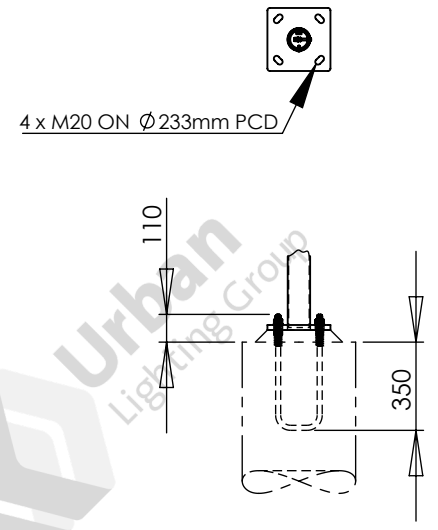
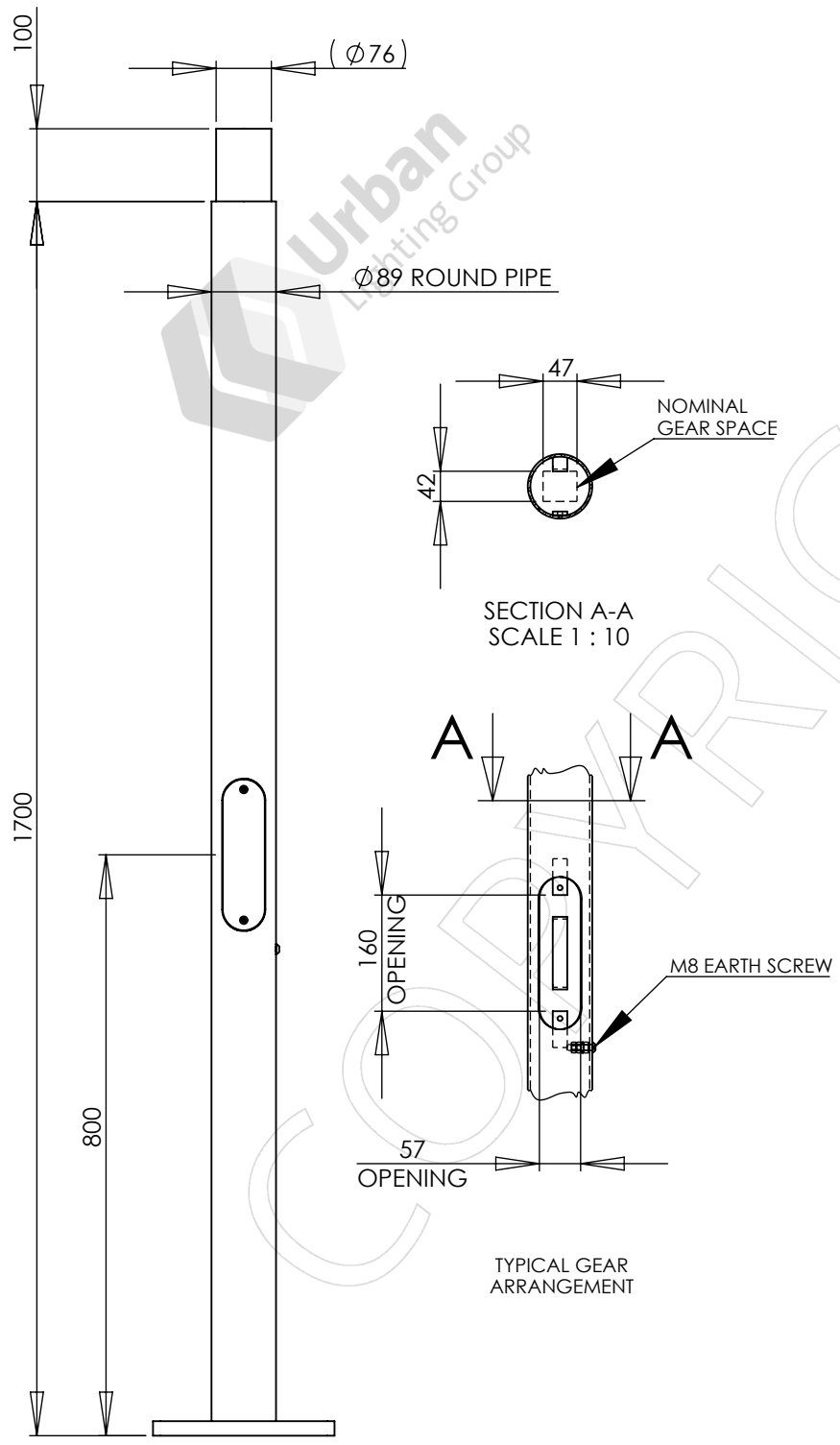

- NOTES:
- LUMINAIRES AND CABLING ARE NOT INCLUDED UNLESS SPECIFICALLY LISTED ON THE QUOTATION.
 - SEE QUOTATION FOR REINFORCING CAGE AND FOOTING DETAILS

DESIGNED AND MANUFACTURED TO:
 AS 1798 LIGHTING POLES AND ARMS - PREFERRED DIMENSIONS
 AS/NZS 1170.2 STRUCTURAL DESIGN ACTIONS - PART 2: WIND ACTIONS
 AS 4100 STEEL STRUCTURES
 AS 4680 HOT-DIP GALVANIZED (ZINC) COATINGS
 SEE DS-3040 FOR OTHER DESIGN STANDARDS

PARTS LIST					
ITEM NO.	PART NUMBER	DESCRIPTION	DRAWING NO.	REV.	QTY.
1	FL1.7P89-4	COLUMN, 1.7m 1 SECTION ROUND PIPE 89 X 3.6	ADL-21833	1	1
2	UBA-M20X233	U-BOLT ASSEMBLY, M20X233 PCD	ADL-20358	3	1

REV.	DESCRIPTION	DATE	BY	APP.	
1	INITIAL ISSUE	2025-01-29	KG	AE	COLUMN, FL1.7P89-4, 1.7m 1 SECTION ROUND PIPE 89 X 3.6
					COATING: GALVANIZED
					MAXIMUM LOAD: 0.60m ² 60kg
					WIND REGION: A, TC 2
					GROUND LOAD: M* 1.41kNm, V* 0.84kN
					WEIGHT: 22.7kg

Urban
Lighting Group
Innovative Streetscape Solutions

Urban Lighting Group Pty Ltd
 ABN 74 638 077 684
 28 National Drive, Hallam Victoria 3803
 T 1300 088 719
 email: sales@urbanlightinggroup.com.au

DRAWING NO. GA-11136
 REVISION 1